

# Installation Manual

**WINEGARD®**  
TRAV'LER®



## Automatic Multi-Satellite TV Antenna

Model SK-1000  
TRAV'LER® DISH® Antenna

To download the manual in color and for up-to-date product and warranty information, visit [winegard.com/sk-1000](http://winegard.com/sk-1000).

For Technical Services, email [help@winegard.com](mailto:help@winegard.com) or call 1-800-788-4417  
For Receivers and Programming, call 1-866-609-9374.

### Product Registration

Please register your Winegard product by completing the online registration form at <http://www.winegard.com/register>.



2452238

# Before Installing the Antenna

You have selected the Winegard® TRAV'LER® automatic multi-satellite TV antenna. The TRAV'LER antenna will deliver the ability to view multiple satellites at the same time with unmatched signal strength, the lowest travel height on the market, maximum HD capabilities and easy to use functionality—just like you get at home. This manual provides important information on the installation and operation of your TRAV'LER antenna on an RV. Please take time to read the manual in its entirety before installing or operating your antenna.

Follow the instructions on this side of the manual if installing the TRAV'LER DISH antenna. For operation instructions, follow the instructions on the reverse side of the manual.

## Specifications

Depending on location and DISH receiver type, the following satellites can be accessed with the SK-1000 during automatic operation: 110°, 119°, 129°.

Height of assembled unit: 9.75"  
Width of assembled unit: 25"  
Length of assembled unit: 42"

Width of mount base: 21"  
Length of mount base: 24"

Unit Weight: 45 pounds  
Shipping Weight: 70 pounds

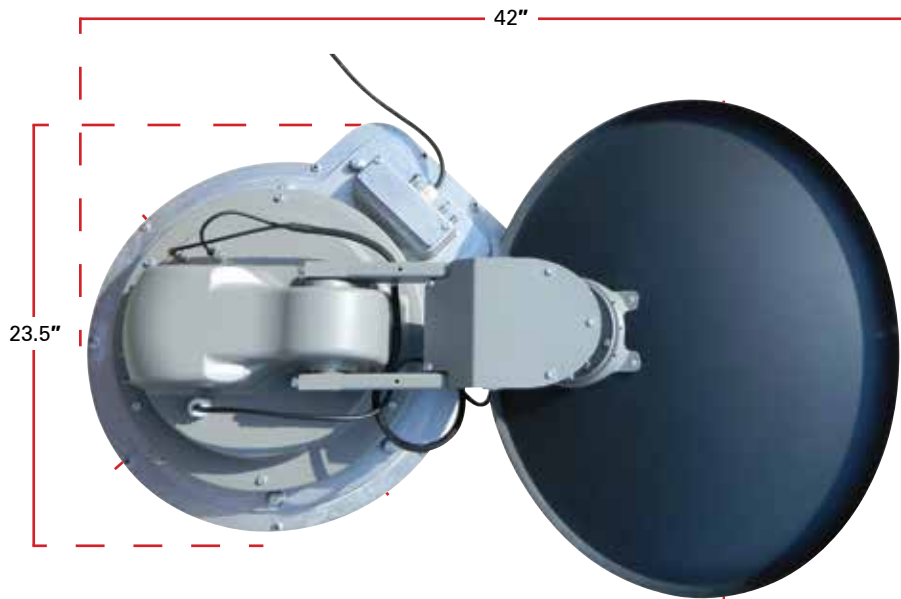

FIGURE 1. Dimensions of SK-1000

## Safety Recommendations

Do not attempt to install this system in the rain or under any wet conditions. Moisture may affect electronics and void your warranty.

Do not paint this antenna. Painting the TRAV'LER antenna will void your warranty.

Pay attention to the pinch points as the antenna raises. The pinch points should be labeled on the antenna (see fig. 2).

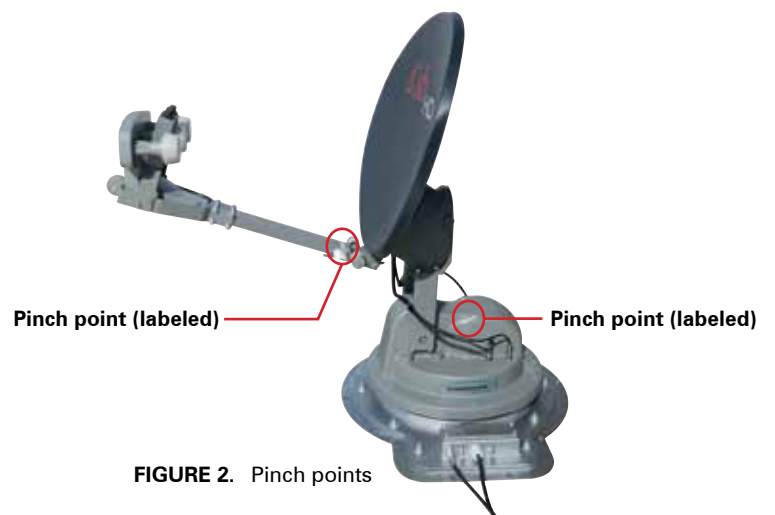

FIGURE 2. Pinch points

# Clearance Requirements

The arm of the TRAV'LER antenna extends 32.5" from the center of the base and may operate only 8" above the surface to which the TRAV'LER antenna is mounted. **To ensure you have adequate clearance for the TRAV'LER antenna to safely operate, check that there are no obstructions taller than 8" within 32.5" of the center of the base.**

**Also, check that there are no obstructions (such as tree limbs) above the antenna that will prevent it from raising.** At its highest point, the antenna will extend to 37" above the roof to which it is mounted (see fig. 3).



FIGURE 3. Range of motion for TRAV'LER SK-1000 antenna

# Parts

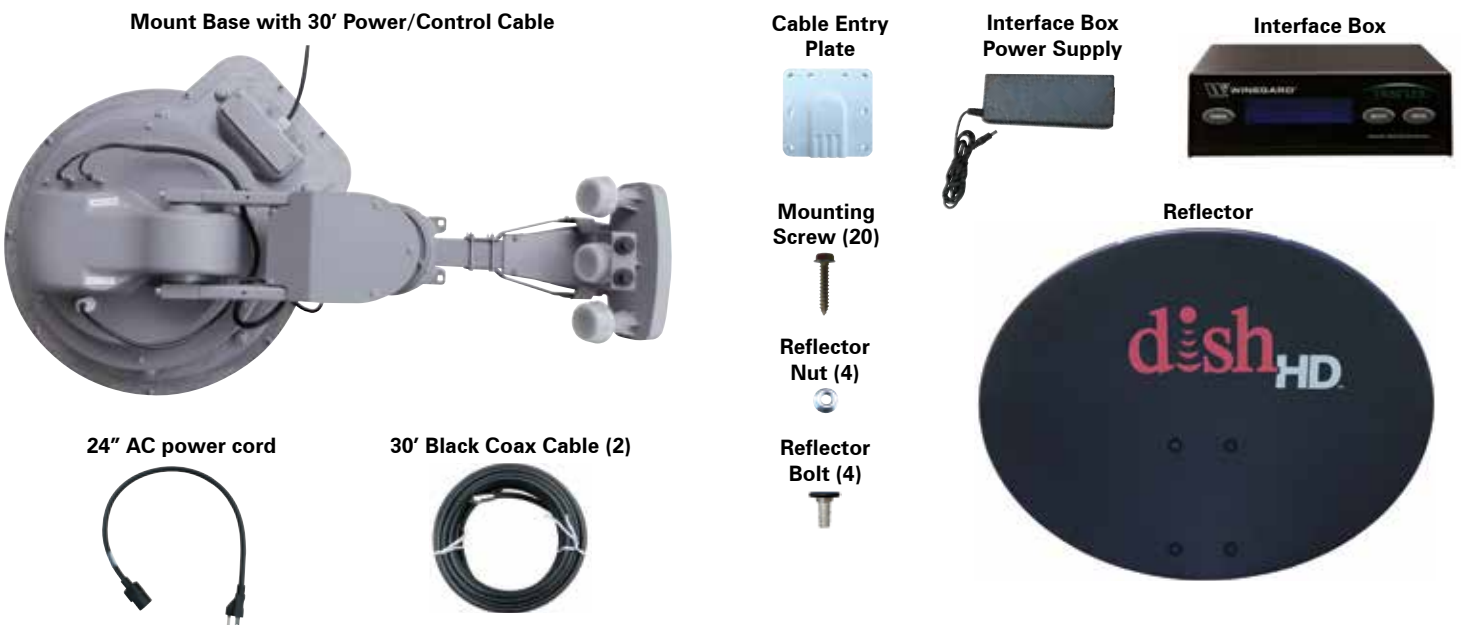

# Choosing a Location for the Antenna

1. For best performance and to reduce signal acquisition time, park the vehicle on a level surface that is free of obstructions such as trees or large buildings. Make sure you have a clear view of the southern sky.
2. Before removing the TRAV'LER antenna from its box, contact your RV dealer or manufacturer. Your RV may be pre-wired or have a reinforced area for this system.
3. Then, choose a location on the roof that meets the following requirements:

- a. Offers enough support for a secure installation
- b. Allows dish to raise and rotate without interference from other roof-mounted equipment
- c. Has a minimum roof space of 42" x 25" for the antenna (see fig. 4)
- d. Lacks obstructions taller than 8" mounted within a 32.5" radius from the center of the TRAV'LER base
- e. Has a gap of less than 3/16" between the bottom of the antenna and the roof

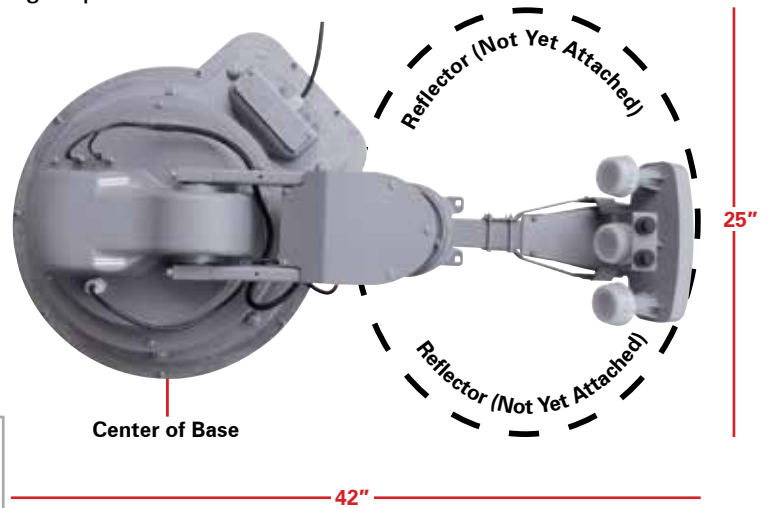

FIGURE 4. Required roof space for antenna

**WARNING** Do not install the antenna in a location where a gap of 3/16" or more exists between the bottom of the antenna and the roof, as the antenna may damage the roof.

- f. Is within 5 degrees of level, or the system may require more time to locate satellites (for best operation, must be within 3 degrees of level).

# Choosing a Location for Cables to Enter the Vehicle

Once you have chosen a location for the TRAV'LER antenna, choose a location for the cables to enter the vehicle. Keep in mind the following:

1. The TRAV'LER interface box must plug into a well-ventilated 110V outlet.
2. The 24" AC power cord must be long enough to extend from the outlet to the interface box power supply, which will then connect to the interface box.
3. The 30' control cable must be long enough to extend from the mount base to the interface box.
4. One 30' coax cable will need to be run from the mount base to each receiver inside the vehicle. Note that the provided coax cables only include a connector on one end.
5. Wires should not be run through the striped area (see fig. 5). Anything in the striped area will interfere with the operation of the TRAV'LER antenna and may cause damage to the object or to the antenna.

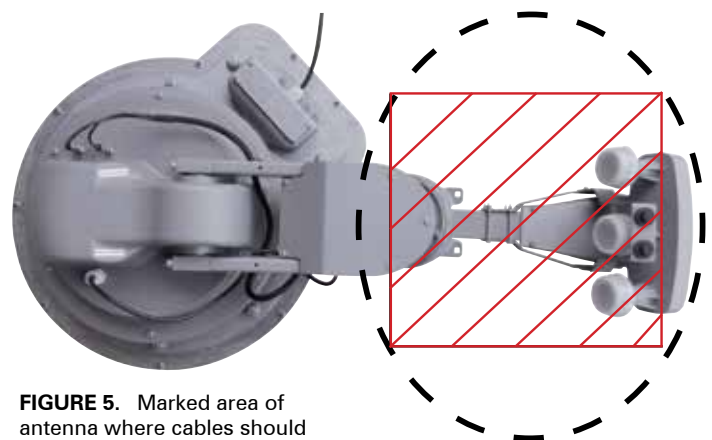

FIGURE 5. Marked area of antenna where cables should not be run

Make sure cables are long enough to reach their destination points inside the vehicle. For cable runs longer than 30', an extension may be purchased. Winegard recommends using Model CL-SK26 25' extension cable. Do not exceed 55' of cable!

**WARNING** Winegard is NOT liable for damage, expenses, or injury caused by improper installation.



# Installing the Antenna

1. Place the TRAV'LER antenna on the roof where you plan to install it. On the mount base, the transition plate is marked "FRONT" and "BACK." Rotate the TRAV'LER antenna until the front of the mount base faces the front of the RV. **The TRAV'LER antenna must be installed on or parallel to the centerline of the coach.** See figure 6.

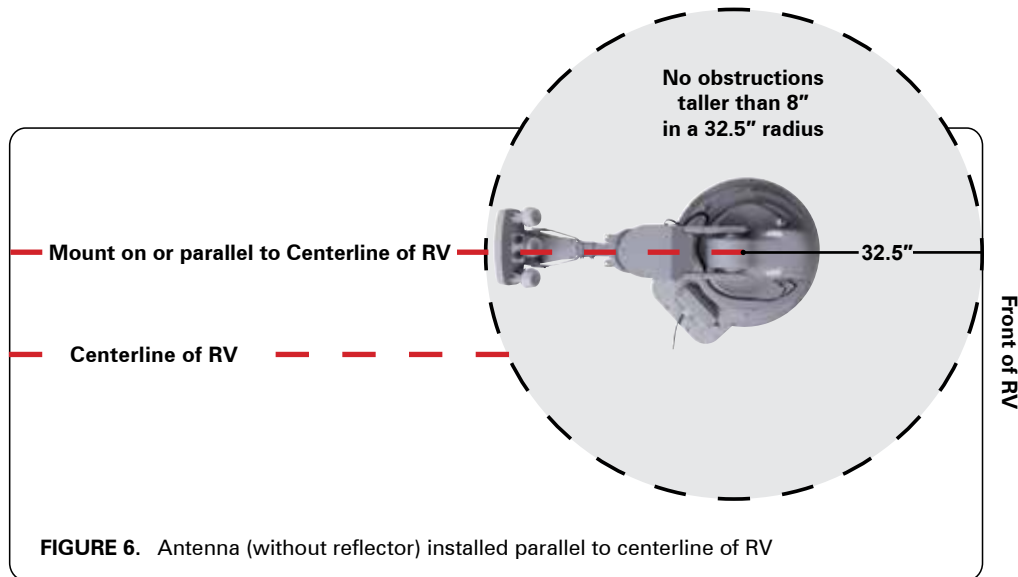

**TIP** When installing the antenna on a rubber roof, Winegard recommends using Model SKA-004 roller plate, which is designed to create a solid landing area for the roller. If not using this plate, make sure that the roller does not come in contact with any rib supports or bubbles in the roof when in operation. Failure to do so may result in damage to the roof.



2. Verify that the marked "FRONT" of the transition plate is facing the front of the vehicle (see fig. 7).



FIGURE 7. Marked "FRONT" of transition plate on fully assembled antenna

3. Mark the location where the nine screw holes will go. It is important that you can see these marks on the roof of the RV. Then, move the mount base out of the installation area. **It is recommended that you do not pre-drill the screw holes at this time.**
4. To prevent water from getting into the mount base, use a solid line of approved sealant to connect the marks in the shape of the base. This step *must* be completed, or the unit will fail due to corrosion. Replace the TRAV'LER antenna base.
5. Before using the supplied mounting screws, check with your vehicle manufacturer for any special screw requirements. Then, screw the antenna base to the roof using nine mounting screws.
6. Run a solid bead of sealant around the edge where the transition plate meets the roof, making sure to cover each screw head. Be careful not to get any sealant above the transition plate.



# Overall Setup

1. Drill a 1" hole in the roof, and push the power/control cable and coax cables through the hole. Place the supplied cable entry plate over the hole and cables, and screw the plate in place using eight of the supplied mounting screws. Seal the plate and screw holes with approved sealant (not included).

**TIP** Depending on the length of the cable on the roof, you may need to use cable clamps between the unit and the cable entry plate. Clamping every 12–16" should eliminate any unnecessary cable movement.

2. Connect the power/control cable running from the mount base to the "DC OUT/ANT. COMM." port of the interface box.
3. Connect the power supply to the "DC IN" port of the interface box.
4. Connect one end of the AC power cord to the power supply and the other end to a 110V outlet.
5. Connect a coax cable from the mount base to each receiver. The receiver(s) should already be connected to the TV(s). Note that the provided coax cable only includes a connector on one end.



**FIGURE 8.** Hopper setup with fully assembled antenna

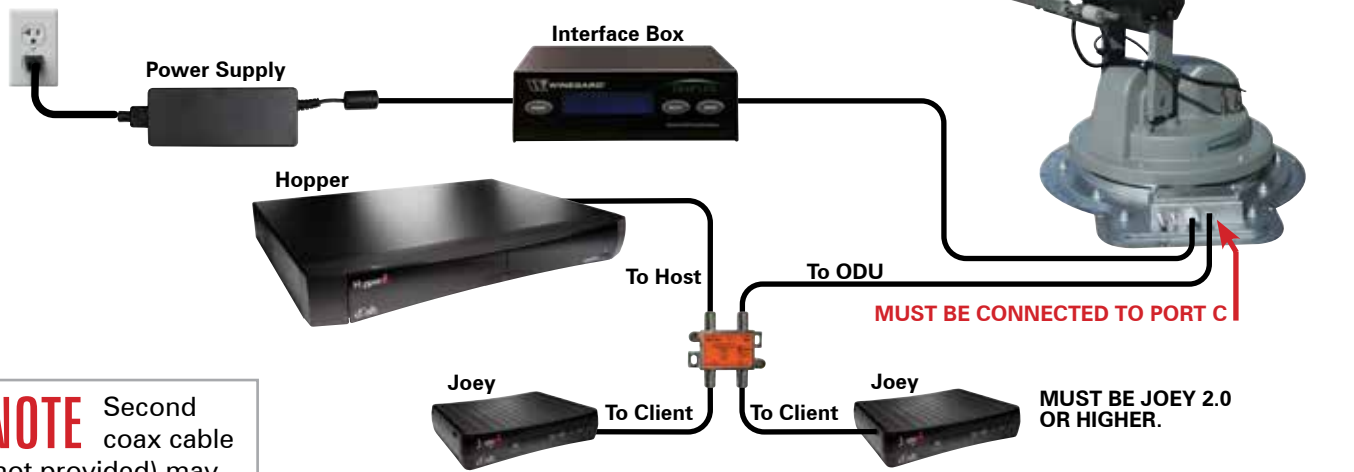

**NOTE** Second coax cable (not provided) may be run for optional receiver or additional wiring capabilities.

**FIGURE 9.** Wally setup with fully assembled antenna

DPH42 Power Inserter and Channel Stack 4-Way Splitter are part of Kit SKDPHPI.

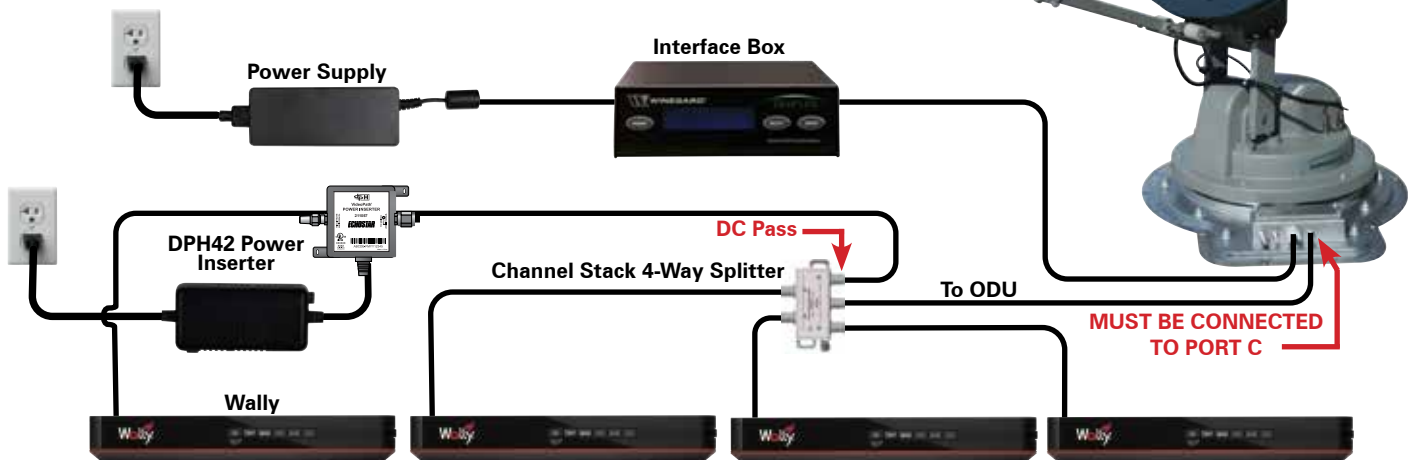

# Installing the Reflector

Once the sealant around the cable entry plate has begun to cure, check that there is nothing above the unit that might prevent the antenna from raising. Then, follow the instructions to raise the antenna for reflector installation. In some cases you may be able to install the reflector with the unit in the stowed position; if so, skip to step 3.

1. Press "POWER," and hold for two seconds to turn on the interface box. Wait until the interface box finishes "connecting to antenna." The TRAV'LER antenna may enter the search routine after ten seconds. **Pay attention to the pinch points as the antenna raises.**
2. As the antenna raises, press "POWER" and "SELECT" at the same time. The antenna should stop moving.
3. Line up the four holes on the reflector with the four holes on the mounting bracket. Insert the four reflector bolts through the four holes on the front of the reflector. Thread a nut onto each bolt, and tighten the nuts.
4. Press and hold "POWER" for two seconds to power on the unit. Press "POWER" again until the interface displays "Stowing..."; this should lower the antenna to the stowed/travel position.

## WINEGARD MOBILE PRODUCTS LIMITED WARRANTY (2 YEARS PARTS; 1 YEAR LABOR)

Winegard Company warrants this product against defects in materials or workmanship for a period of two (2) years from the date of original purchase. During year one (1) of such warranty, Winegard Company will also pay authorized labor costs to an authorized Winegard dealer to repair or replace defective products. No warranty claim will be honored unless at the time the claim is made, Customer presents proof of purchase to an authorized Winegard dealer (to locate the nearest authorized Winegard dealer, contact Winegard Company, 3000 Kirkwood Street, Burlington, Iowa 52601, Telephone 800-288-8094 or visit [www.winegard.com](http://www.winegard.com)). Customer must provide proof of purchase with a dated sales receipt for the Winegard product to verify the product is under warranty. If the date of purchase cannot be verified, the warranty period shall be considered to begin thirty (30) days after the date of manufacture.

If a defect in material or workmanship is discovered, Customer may take the product to an authorized Winegard dealer for service. Customer must provide proof of purchase to verify the product is under warranty. If the product is brought to an authorized Winegard dealer for service prior to expiration of year one (1) of the warranty period and a defect in material or workmanship is verified by Winegard Technical Services, Winegard Company will cover the Winegard dealer's labor charges for warranty service. The Winegard dealer must contact Winegard Technical Services in advance for pre-approval of the service. Approval of the service is at the sole discretion of Winegard Company.

Alternatively, Customer may ship the product prepaid to Winegard Technical Services (located at 2736 Mt. Pleasant Street, Burlington, Iowa 52601, Telephone 800-788-4417). Customer must return the product along with a brief description of the problem and provide Winegard Technical Services with Customer's name, address, and phone number. Customer must also provide proof of purchase to verify the product is under warranty. If the product is returned before the expiration of the warranty period, Winegard Company will (at its option) either repair or replace the product.

This Limited Warranty does not apply if the product has been damaged, deteriorates, malfunctions or fails from: improper installation, misuse, abuse, neglect, accident, tampering, modification of the product as originally manufactured by Winegard in any manner whatsoever, removing or defacing any serial number, usage not in accordance with product instructions or acts of nature such as damage caused by wind, lightning, ice or corrosive environments such as salt spray and acid rain. This Limited Warranty also does not apply if the product becomes unable to perform its' intended function in any way as a result of the television signal provider making any changes in technology or service.

### RETURN AUTHORIZATION POLICY

A Return Material Authorization (RMA) is required prior to returning any product to Winegard Company or Winegard Warranty Services under this warranty policy. Please call our Technical Services Department at 800-788-4417 or send an e-mail to [warranty@winegard.com](mailto:warranty@winegard.com) to obtain the RMA number. Please furnish the date of purchase when requesting an RMA number. Enclose the product in a prepaid package and write the RMA number in large, clear letters on the outside of the package. To avoid confusion or misunderstanding, a shipment(s) without an RMA number(s) or an unauthorized return(s) will be refused and returned to Customer freight collect.

WINEGARD COMPANY DOES NOT ASSUME ANY LIABILITIES FOR ANY OTHER WARRANTIES, EXPRESS OR IMPLIED, MADE BY ANY OTHER PERSON.

ALL OTHER WARRANTIES WHETHER EXPRESS, IMPLIED OR STATUTORY INCLUDING WARRANTIES OF FITNESS FOR A PARTICULAR PURPOSE AND MERCHANTABILITY ARE LIMITED TO THE TWO YEAR PERIOD OF THIS WARRANTY.

In states that do not allow limitations on implied warranties, or the exclusion of limitation of incidental or consequential damages, the above limitations or exclusions do not apply.

Some states do not allow limitations on how long an implied warranty lasts, or the exclusion of limitation of incidental or consequential damages, so the above limitations or exclusions may not apply to you.

This warranty gives Customer specific legal rights. Customer may also have other rights that may vary from state to state.

### SATELLITE RECEIVER WARRANTY

See manufacturer's limited warranty policy.

WS-MOBWARREV3

**Disclaimer:** Although every effort has been made to ensure that the information in this manual is correct and complete, no company shall be held liable for any errors or omissions in this manual. Information provided in this manual was accurate at time of printing. Winegard and TRAV'LER are registered trademarks of Winegard Company. DISH & Hopper are registered trademarks of DISH Network L.L.C.

# Operation Manual

**WINEGARD®**  
TRAV'LER®



## Automatic Multi-Satellite TV Antenna

Model SK-1000  
TRAV'LER® DISH® Antenna

To download the manual in color and for up-to-date product and warranty information, visit [winegard.com/sk-1000](http://winegard.com/sk-1000).

For Technical Services, email [help@winegard.com](mailto:help@winegard.com) or call 1-800-788-4417  
For Receivers and Programming, call 1-866-609-9374.

### Product Registration

Please register your Winegard product by completing the online registration form at <http://www.winegard.com/register>.



2452238



# Operation for DISH Users

The TRAV'LER antenna offers a simple one-button operation. Simply press "POWER," and the antenna will automatically begin searching for satellites. The instructions assume that the antenna is already in the stowed position.

1. Press and hold "POWER" for two seconds or until the TRAV'LER interface displays "POWER ON."
2. Once the unit has been powered on, release "POWER."
3. The interface screen will display the type of satellite dish on the top line.

WINEGARD COMPANY  
POWER ON

connecting to  
antenna

SM Dish 1000  
Ready: Multi-Sat

4. The TRAV'LER antenna will enter the search mode as part of its normal operation and will display "Searching" on the bottom line.
5. The antenna will find its home position and begin to look for a satellite. Upon finding a satellite, the antenna will fine-tune or "peak" on the signal.
6. In automatic search mode, the TRAV'LER antenna will lock onto three different satellites: 119°, 110°, and 129°. The antenna will display an asterisk for each satellite found.

SM Dish 1000  
Searching...

SM Dish 1000  
Home EL...

SM Dish 1000  
\*119 \*110 \*129

7. Continue to page 3 if setting up the receiver for the first time or if setting up the receiver after moving the receiver from the house to the RV. If the receiver is already set up in the RV, you are now ready to watch TV!

**TIP** To turn off the power to the TRAV'LER antenna after the antenna has locked onto satellites, press "POWER" and "SELECT" at the same time.

Before traveling, make sure to press "POWER" and wait for the antenna to start to power up; then press "POWER" again to initiate the stow sequence. See below for information on stowing before traveling.

## User Menu

The interface includes a user menu for some advanced features. The options most commonly used are the ability to change the dish type, check software/hardware versions, change desired satellite configuration, or manually move the dish.

**WARNING** Improper use of the user menu could cause damage to the TRAV'LER antenna and/or vehicle. Follow all instructions when entering the user menu for manual operation. See page 3.

## Ready to Travel?

The TRAV'LER antenna is not meant for use while traveling. To stow the unit when you are ready to travel, press "POWER" one time. The unit will stop what it is doing and return to the stowed position. The TRAV'LER interface will not turn off unless the TRAV'LER antenna is successfully stowed. Visually inspect that the antenna is in the stowed/travel position before traveling. Do not move the vehicle until the TRAV'LER antenna is stowed.

## Emergency Manual Stow

If unable to stow the TRAV'LER antenna, it may be necessary to use emergency manual stow. Emergency manual stow is meant as a last resort and is not meant for common usage! To use emergency manual stow, unplug the interface box. Then, remove the black plastic bolt from the back of the mount. Insert a 5/16" socket extension into this auxiliary drive. Turn the auxiliary drive clockwise to lower the unit. Do not use a drill!

## Emergency Power Off

The antenna comes with an emergency power off feature. To activate it, press and hold "POWER" and then press "SELECT" while still holding "POWER". The TRAV'LER antenna will stop and turn off. If the emergency power off feature is used, the antenna may not be in a safe position for travel. Do not move the vehicle until the unit is stowed.

# Manual Operation

The TRAV'LER antenna is a versatile satellite antenna and can be manually set to find many different satellites individually. This function is rarely used. The instructions assume that the antenna is already in the stowed position. Note: Diagnostics and Installation menus are not required for normal operation and should only be entered by a trained professional.

1. Press and hold "POWER" for two seconds or until the TRAV'LER interface displays "POWER ON." Then, press and hold "ENTER" for two seconds.

WINEGARD COMPANY  
POWER ON

2. The interface will ask if you wish to enter the user menu. Press the Select button to choose "Yes," and then press the Enter button to confirm the selection.

Enter User Menu?  
\*Yes No

3. The user menu consists of four choices: Search Mode, Diagnostics, Installation, and Exit. Press the Enter button to choose Search Mode.

Search Mode\*  
Diagnostics

4. In the Search menu, choose from the following: Multi-Sat Mode (normal search mode), Manual 110, Manual 119, Manual 129, Main Menu (returns to the user menu) or Exit (enters the search routine). Press the Select button to cycle through satellites until the asterisk is next to the satellite you wish to find. Press "ENTER" to confirm the selection.

Multi-Sat Mode\*  
Manual 61

5. The interface will ask you to confirm the change. Press "SELECT" to move the asterisk to "Yes." Then, press "ENTER" to confirm the selection.

The TRAV'LER interface will then acknowledge which satellite has been selected. Press the Enter button.

Manual ##  
Selected

6. The interface will ask if you want to turn the power off. Press the Enter button to choose "No" and start a new search for your chosen satellite. Press "SELECT" then "ENTER" to choose "Yes" and turn off the antenna.

The TRAV'LER antenna will remain in manual mode until you select "Multi-Sat Mode" again.

Power OFF?  
\*Yes No

DISH Receiver Setup on following page.

# DISH Receiver Setup

The following instructions assume that the TRAV'LER antenna has found and locked onto satellites 110°, 119°, and 129°. There should be an asterisk next to 110°, 119°, and 129° on the TRAV'LER interface. The following instructions are based on Hopper3 or Wally receiver. If your receiver differs from the options shown below, you may need to consult your receiver manual. The wording and display used in your receiver may differ slightly.

For Technical Services, email [help@winegard.com](mailto:help@winegard.com) or call 1-800-788-4417



Power on the Hopper3, once powered the Hopper3 will automatically try to configure to the TRAV'LER



Please wait until you receive the "Starting up..." screen, from this screen you will either receive an "Acquiring Signal" screen or an error code.



If the progress bar downloads you are now ready to watch TV. If it fails and you receive an error code, please proceed to the next steps.



Verify the wiring from the Hopper3 to the TRAV'LER. Once verified press the Home button three times

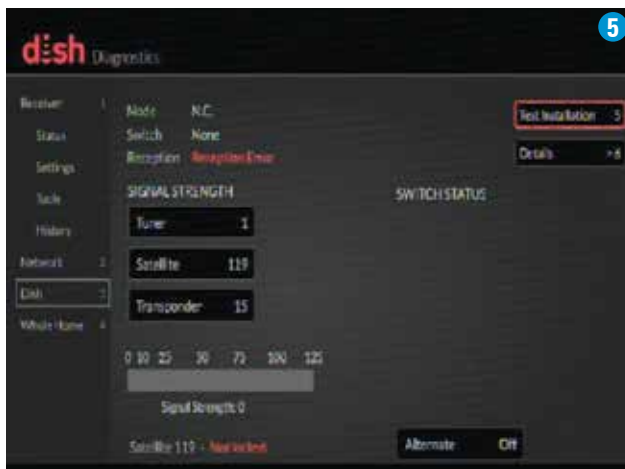

On the diagnostics screen press the number "3" on the Hopper remote to select the Dish settings. Once in the Dish setting press number "5" on the remote to Test Installation.

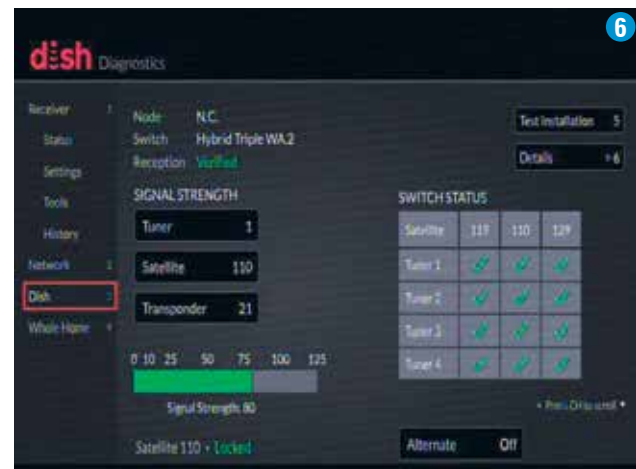

If everything installed properly you will have green check marks next to the satellites with a Hybrid Triple WA.2 switch installed. If you still have issues please contact Customer Support at 800-288-8094.

# Troubleshooting

<b>ANTENNA CONNECTION FAILED</b>	Check the data cable connection on the back of the interface box. It may not be connected properly.
<b>EL HOME FAILURE</b>	Something is preventing the mount from raising as it attempted to find the HOME position. Look for obstructions if the unit has recently been manually raised or if the electronics have been replaced. The calibration may need to be reset. Contact Winegard Technical Support at <a href="mailto:help@winegard.com">help@winegard.com</a> or 1-800-788-4417.
<b>AZ MOTOR STALLED</b>	Something is preventing the mount from rotating; look for obstructions. If there is no obvious obstruction, contact Winegard Technical Support at <a href="mailto:help@winegard.com">help@winegard.com</a> or 1-800-788-4417.
<b>EL MOTOR STALLED</b>	Something is preventing the mount from raising or lowering; look for obstructions. If there is no obvious obstruction, contact Winegard Technical Support at <a href="mailto:help@winegard.com">help@winegard.com</a> or 1-800-788-4417.
<b>SK MOTOR STALLED</b>	Something is preventing the reflector and LNBF from rotating; look for obstructions. If there is no obvious obstruction, contact Winegard Technical Support at <a href="mailto:help@winegard.com">help@winegard.com</a> or 1-800-788-4417.
<b>STOW FAILURE ANT NOT STOWED</b>	The TRAV'LER antenna is not stowed. Do not try to move the vehicle. Try to stow the TRAV'LER antenna again. If it fails again, check for obstructions.
<b>STOW FAILURE STOW UNKNOWN</b>	Check the data cable connection on the back of the interface. It may not be connected properly.
<b>AZ MOTOR RUN REVERSE</b>	Contact Winegard Technical Support at <a href="mailto:help@winegard.com">help@winegard.com</a> or 1-800-788-4417.
<b>EL MOTOR RUN REVERSE</b>	Contact Winegard Technical Support at <a href="mailto:help@winegard.com">help@winegard.com</a> or 1-800-788-4417.
<b>SK MOTOR RUN REVERSE</b>	Contact Winegard Technical Support at <a href="mailto:help@winegard.com">help@winegard.com</a> or 1-800-788-4417.
<b>AZ MOTOR RUNAWAY</b>	Contact Winegard Technical Support at <a href="mailto:help@winegard.com">help@winegard.com</a> or 1-800-788-4417.
<b>EL MOTOR RUNAWAY</b>	Contact Winegard Technical Support at <a href="mailto:help@winegard.com">help@winegard.com</a> or 1-800-788-4417.
<b>SK MOTOR RUNAWAY</b>	Contact Winegard Technical Support at <a href="mailto:help@winegard.com">help@winegard.com</a> or 1-800-788-4417.
<b>NO LNB VOLTAGE</b>	The TRAV'LER antenna is not seeing the required 12–18VDC needed to power the LNBF. Check the coax connections. If these are all connected properly, contact Winegard Technical Support at <a href="mailto:help@winegard.com">help@winegard.com</a> or 1-800-788-4417.
<b>UNKNOWN ERROR #####</b>	Contact Winegard Technical Support at <a href="mailto:help@winegard.com">help@winegard.com</a> or 1-800-788-4417.
<b>C MOTOR NOT FOUND</b>	Contact Winegard Technical Support at <a href="mailto:help@winegard.com">help@winegard.com</a> or 1-800-788-4417.
<b>ANTENNA WILL NOT AUTOMATICALLY STOW</b>	See emergency manual stow instructions in the operation manual.